



UNSURPASSED QUALITY IN COUNTERTOPS & WORKSURFACES

ORDERING & INSTALLATION GUIDE

FOR NEW OR REPLACEMENT COUNTERTOPS

FORMATOP



WWW.FORMATOP.COM

ORDERING YOUR FORMATOP

NEW OR REPLACEMENT COUNTERTOP



PRELIMINARY CONSIDERATIONS

Before ordering or measuring for your new or replacement countertops there are some decisions to be made beyond the colour and texture.

Style of Countertop:

Countertops come in two basic styles, Postform or Straight Edge.

Postform is the most popular of all countertop styles. The laminate top surface is cemented to a particle board core which has the front and back edges shaped to a requested profile. The laminate is then one continuous form from the leading edge to the back of the countertop. This no-seam construction prevents moisture from entering. Postform also offers a variety of front edge profiles. Check with your Formatop dealer for the many profiles that are available.



POSTFORM

Straight Edge or Self Edge appears just as it sounds. All horizontal and vertical surfaces are at right angles. This style has seams where the different surfaces meet, so care must be taken to prevent moisture from getting into joints. Solid surface materials or wood edge treatments can be applied to the edges instead of laminate.



STRAIGHT EDGE

Build-up or Non Build-up

To allow doors or drawers to open properly the countertop may have to be raised to allow clearance (diagram 1). Blocks of wood 11/16" high may be added under the countertop where it sits on the frame.

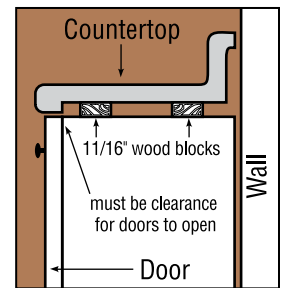

DIAGRAM 1

End Treatment Options

All end treatments must be taken into consideration when measuring for new or replacement countertops.

Finished End

For exposed countertop ends (those not ending against a wall) allow approximately 1" overhang past cabinets. **END CAP KITS** are available from your Formatop dealer.

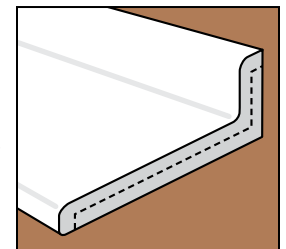

FINISHED END DIA. 2

Appliance Finished End

For exposed countertop ends butting up to appliances, a 1" overhang may not be possible or desirable. For appliance finished ends 1/8" to 1/4" is the recommended overhang depending on size of appliance opening. Appliance Finished Ends can only be used with **NON** Build-up countertops.

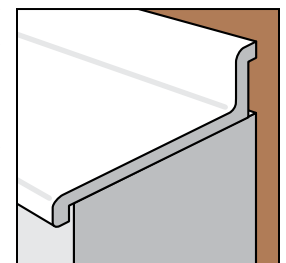

APPLIANCE FINISHED END DIA. 3

Radius Finished End

These can be either single or double radius and must be specified as such. The edge butting a wall would not have a radius end. Radius ends require sufficient overhang past cabinets.

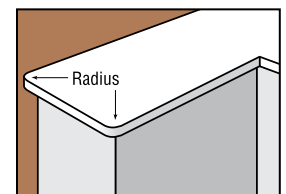

RADIUS FINISHED END DIA.4

End Splash

This is an optional piece used when the countertop end meets a wall. If you wish an end splash incorporated in your countertop design please specify. Formatop will incorporate this into the overall countertop measurement you supply. **END SPLASH KITS** can be supplied with countertop if specified. Refer to installation instructions contained in End Splash Kit.

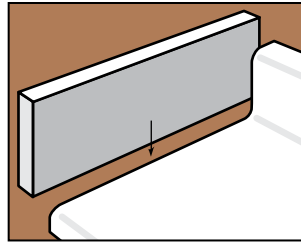

END SPLASH DIA. 5

Bar Sweep Finished End

A symmetrical arc used for Bartops and free-standing Islands. The radius must be included in the overall length of the countertop. This design requires sufficient overhang past the cabinets. A laminate edge is applied to finish the sweep.

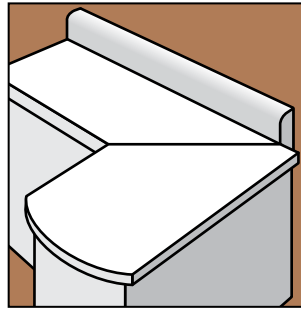

BAR SWEEP FINISHED END DIA. 6

Angle Finished End

These can be either single or double. Size must be specified in final measurements. Allow for sufficient overhang past the cabinets.

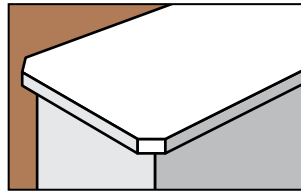

ANGLE FINISHED EDGE DIA. 7

Banjo Top

Cabinet depth is important. Allow an extra 1 1/2" on the banjo or wide side of the cabinet. This design is used primarily for bathroom countertops where there is a shelf running behind toilet. Check with your Formatop dealer if there are any questions about measuring or specifications.

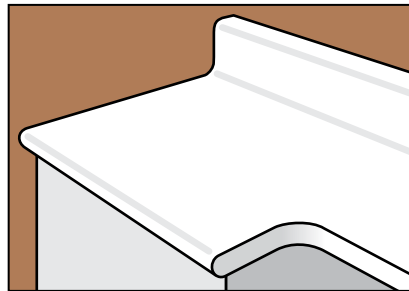

BANJO TOP DIA. 8

FORMATOP MITRE COLLECTION

Formatop offers a wide variety of countertop configurations. Shown on the right are some of the mitre designs that are available in various dimensions. Mitred sections are required for various segments of the countertop construction where, because of laminate size restrictions and corner angles, the countertop must be made in pieces. Sizes under 7 ft. x 7 ft. can be delivered fully assembled by Formatop. Sizes beyond this are restricted because of delivery truck dimensions and home interior limitations, i.e. doorways.

FORMATOP MITRE COLLECTION

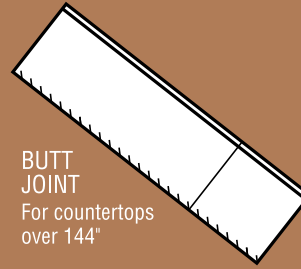

BUTT JOINT
For countertops over 144"

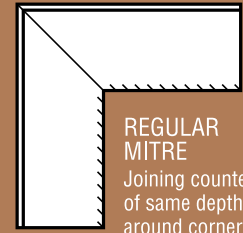

REGULAR MITRE
Joining countertops of same depth around corners

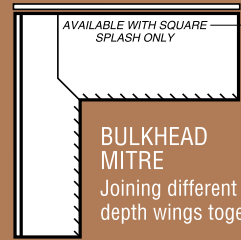

BULKHEAD MITRE
Joining different depth wings together

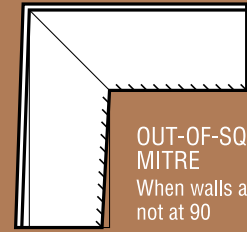

OUT-OF-SQUARE MITRE
When walls are not at 90



DOG LEG (ZIG-ZAG) MITRE
Joining different depth wings, maintaining standard Postform backsplash

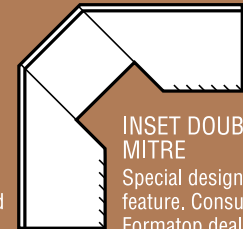

INSET DOUBLE MITRE
Special design feature. Consult your Formatop dealer

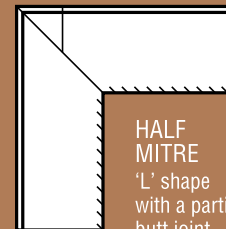

HALF MITRE
'L' shape with a partial butt joint

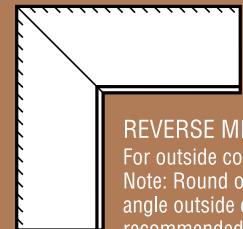

REVERSE MITRE
For outside corner. Note: Round or angle outside corner recommended

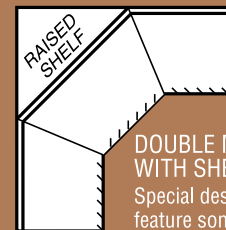

DOUBLE MITRE WITH SHELF
Special design feature sometimes used for corner appliance (sink, cooktop)

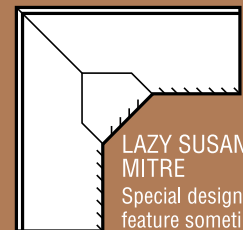

LAZY SUSAN MITRE
Special design feature sometimes used for corner appliance (sink, cooktop)



INSET LAZY SUSAN MITRE
Special design feature. Consult your Formatop dealer

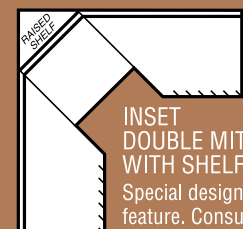

INSET DOUBLE MITRE WITH SHELF
Special design feature. Consult your Formatop dealer

MEASURING FOR NEW OR REPLACEMENT COUNTERTOPS

When measuring for new or replacement countertops, it is imperative that the dimensions be as accurate as possible. Details such as wall squareness, end treatments, and end splash should be noted carefully.

Your Formatop dealer can help you with any mitre or dimension questions. Use the enclosed measurement guide on page 6 to help you calculate your countertop design.

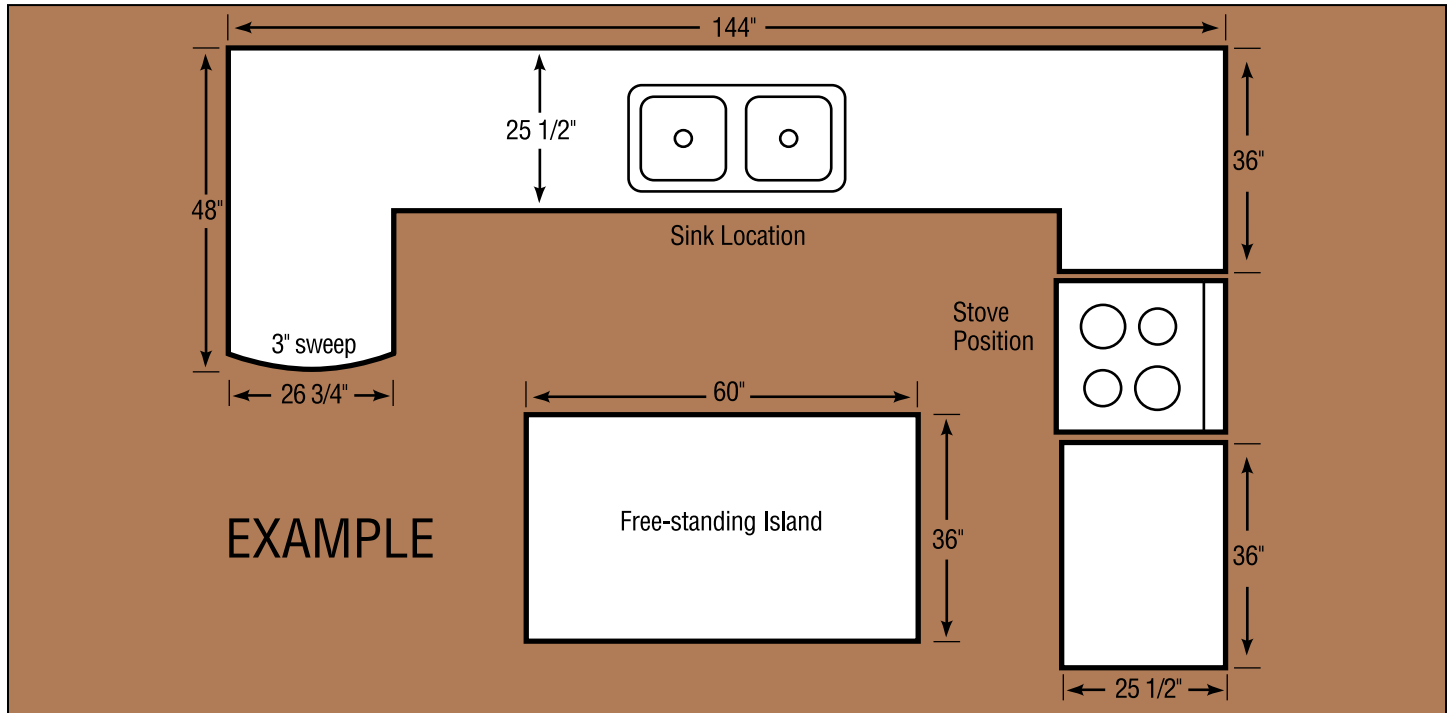

REPLACING EXISTING COUNTERTOPS

If the countertops are being replaced without any changes to the layout, then you can simply measure the existing countertops (see diagram above).

1 Measure the total length of each piece of the countertop along the back where the countertop meets the wall. Measure the width of each piece of countertop. Include any backsplash dimensions within your measurements. Measure each additional piece of countertop, taking care to measure to the nearest 1/8".

2 FOR ISLANDS AND BARTOPS. For islands measure the length and width of the countertop and indicate square, radius or diagonal corners. For bartops measure the width and the length from the wall to the end of the bartop. Indicate size of sweep or radius if required (see diagram 6).

Verify 90 degree corners

Where two walls meet behind countertop, it is important to verify that they are at a 90 degree angle (diagram 9). On

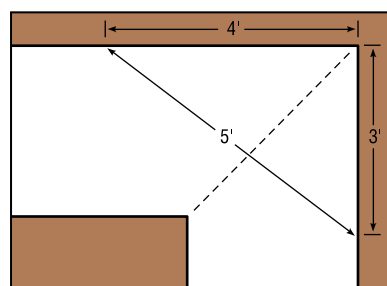

DIAGRAM 9

one wall measure 3 ft. from the corner and on the adjoining wall measure 4 ft. from the corner. Mark these positions carefully. Measure the diagonal between the two points. This distance should be 5 ft. (60") for a 90 degree corner. If your measurement is less than 59 3/4" or more than 60 1/4" make sure you note this on your measurements.

For Diagonal Corners

Measure dimensions A-B and C-D. Make sure that you include the backsplash depth (see diagram 10). Also include measurements 1-2, 3-4, 5-6, 2-7.

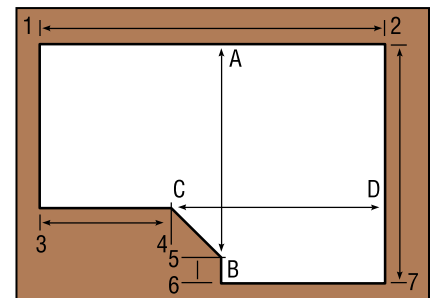

DIAGRAM 10

End Finishes

Specify the type of end finish (see diagrams 2 to 7) including necessary radius or angle dimensions.

NOTE: Indicate whether the countertop requires Build-up (see diagram 1).

INSTALLING YOUR FORMATOP COUNTERTOPS

Formatop countertops come in stock lengths and widths and can be cut to your finished sizes. Pre-mitred countertops are also available through your Formatop dealer. For exposed or appliance ends Formatop supplies kits that contain preshaped laminate strips.

REQUIRED TOOLS AND MATERIALS

Tools:

- Tape Measure • Pencil • Straight Edge • Level
- Framing Square • Caulking Gun • Belt Sander
- Screwdriver • Jigsaw • Compass • Iron • Wrench
- Medium Wood File • Drill • Clamps • Hammer

Materials:

- Formatop Countertop • Latex Silicone • Mitre Bolts
- 1/2" Wood Screws • End Cap Kit

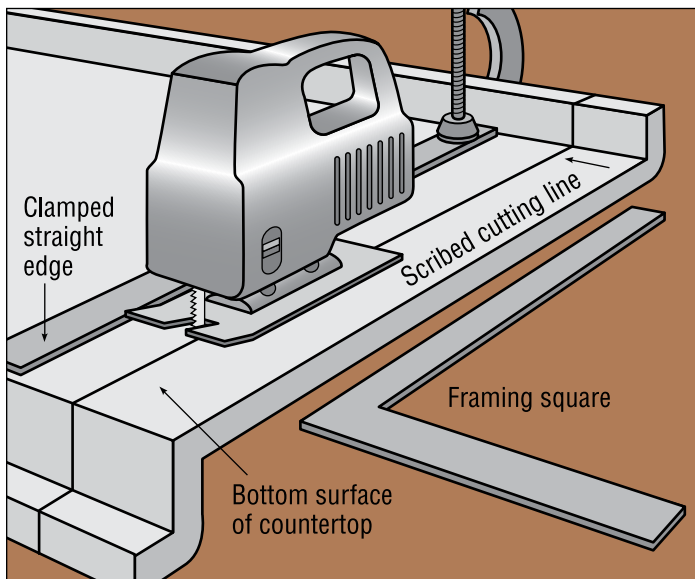

1 When a Formatop standard length countertop is purchased from your dealer, it may not be the exact size you require and will have to be cut to fit. Accurately measure to establish your length requirements. Mark the required cutting line, using a framing square, on the underside surface of the countertop. Using a jigsaw, cut off the countertop on your prescribed line. Use a clamped straight edge as an accurate guide. Cut carefully to avoid chipping laminate surface.

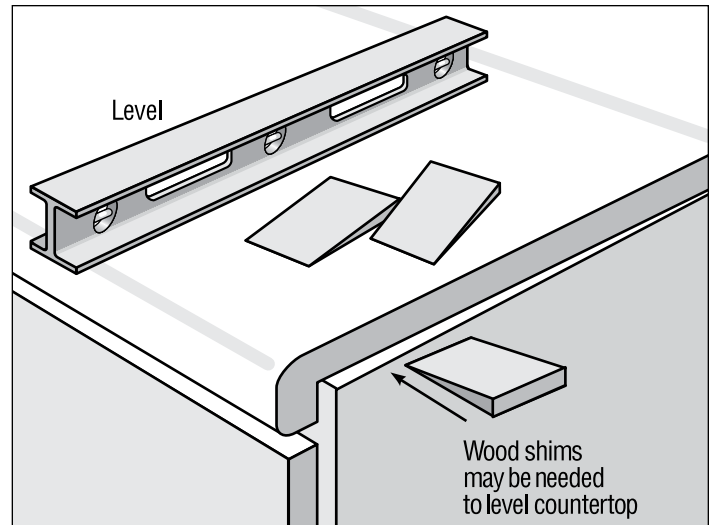

2 Place new countertop sections on cabinets and check fit and dimensions. The countertop front should be parallel to the front of the cabinets. Make sure there is clearance to open the cabinet doors or drawers. If the countertop needs to be raised up to allow clearance (see Build-up), fix 11/16" wood blocks under countertop at points where it sits on the frame of the cabinets. Check to see that the countertop is level. If not this may necessitate using wood shims to level countertop.

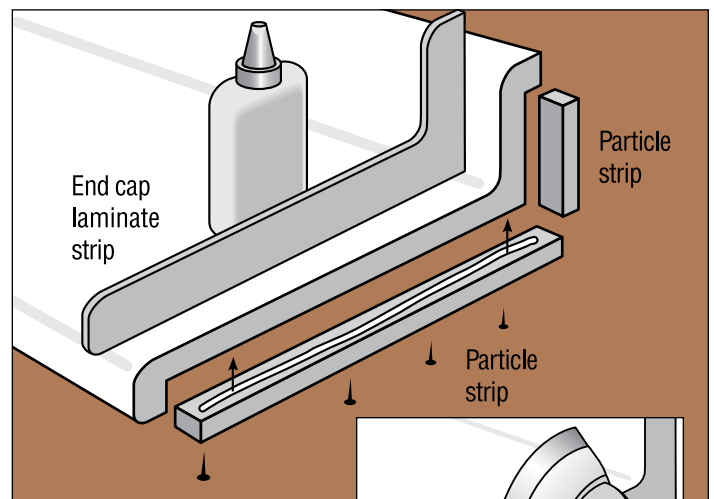

End Cap Components

3 Prior to finishing installation, apply included end caps. Attach the particle strips included in the End Cap Kit (see diagram above). Apply end cap laminate by holding against countertop end, allowing for slight overlap of edges. To activate the glue on the end cap laminate, use an iron set at maximum heat. It is preferable to use a damp cloth between the iron and the laminate and

YOUR NEW COUNTERTOP

Shown below is a handy measurement guide to use in configuring your new or replacement countertop. Outline your countertop according to the dimensional scales. Specify countertop **NOT** cabinet sizes. Be sure to indicate wall locations.

Indicate end treatments and mitres as shown in previous diagrams. Please fill out the necessary information at the bottom of the page pertaining to colour choice, model and finish. Your Formatop dealer can assist you with any questions you may have.

A large grid for drawing a countertop layout. The grid is 15 units wide and 13 units high. The horizontal axis is labeled 1 through 15, and the vertical axis is labeled 1 through 13.

NAME _____

COLOUR _____

ADDRESS _____

MODEL _____

CITY _____ POSTAL CODE _____

FINISH _____

TEL: (HOME) _____ (BUS.) _____

DATE ORDERED _____

PLAN CHECKED BY _____

Formatop Manufacturing Company Ltd.

UNSURPASSED QUALITY IN COUNTERTOPS & WORKSURFACES

REMOVING OLD COUNTERTOPS

CAUTION: Be sure to turn off all water at shut-off valves, then disconnect and remove all plumbing fixtures before removing countertop. If you are not sure, check with your plumber. Move all appliances out of the way so they won't be scratched or damaged.

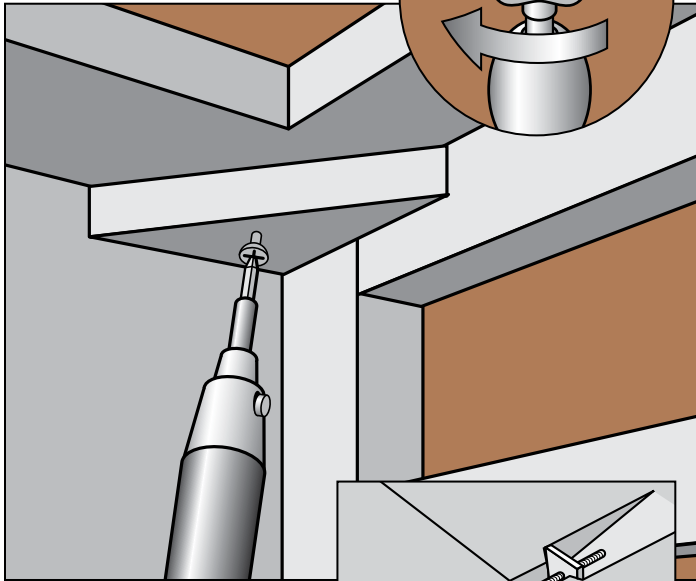

1 Remove all brackets or braces holding countertop to cabinet frame. In mitred areas unscrew and remove any mitre bolts (see installation).

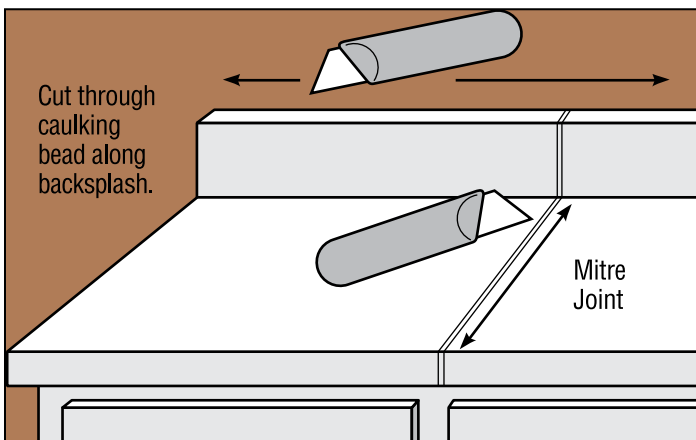

2 Caulking beads along the backsplash, countertop edges and mitre joints should be cut with a sharp utility knife. Any trim around the countertop edge should be removed.

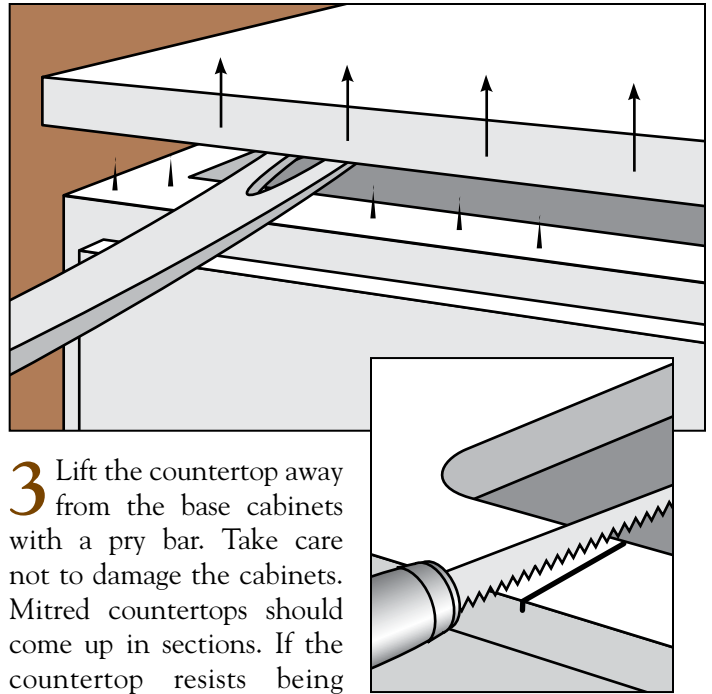

3 Lift the countertop away from the base cabinets with a pry bar. Take care not to damage the cabinets. Mitred countertops should come up in sections. If the countertop resists being pried up, it may be necessary to cut the top in pieces. Using a coarse wood cutting blade in a jigsaw or reciprocating saw, cut the top into easily removable sections. **Take great care not to cut into the cabinets.**

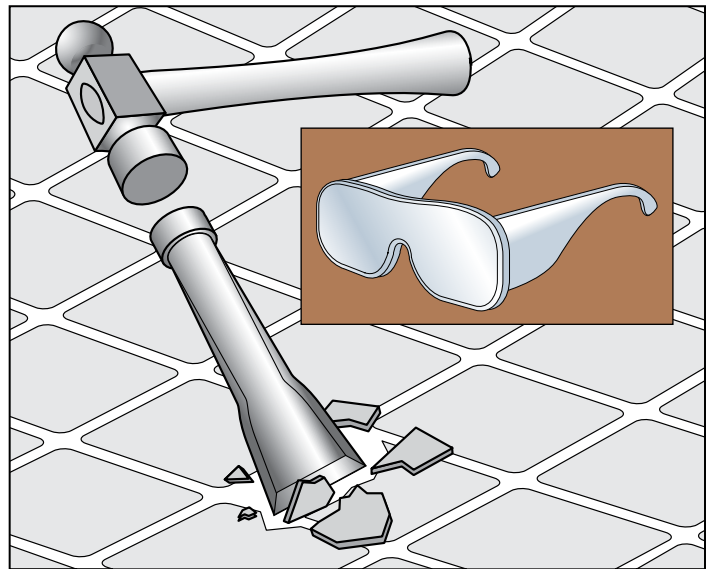

4 Some old countertops are made of ceramic tile set in a masonry base. To remove the tile, chip it away from the base using a masonry chisel and hammer. **To prevent injury wear protective glasses.** Cut the remaining mortar bed into pieces using a circular saw with a masonry cutting blade. If any damage occurs to cabinets during this process, be sure to repair them and check the level.

COUNTERTOPS FOR NEW CABINETS

When measuring for completely new countertops it is extremely important that you know the exact dimensions of the new cabinets. Measure the total length of each cabinet section along the back wall (see diagram below, example dimensions 130", 36", 36"). Measure the depth of the cabinets excluding the thickness of the doors. **Standard kitchen cabinet depth is 24"**. For countertop depth allow for overhang past cabinet (standard overhang is 1 1/2"). The depth of the countertop would then be 24" + 1 1/2" = 25 1/2". This is Formatop's standard countertop depth.

For end treatment measurements and options, view diagrams 2, 3, 4, 5, 6, 7.

Verify that all corners are 90 degrees (see diagram 9).

For free-standing Island cabinets measure the width and the length (example 36" and 84"). The countertop dimensions should allow for overhang on all four sides. Allow for a minimum of 1 1/2" overhang on all sides. If there is to be a seating area on one or more sides of the island, then the dimension of the overhang will have to be increased. Overhangs larger than 12" will require additional support from the cabinet.

Use the dimension graphic on page 6 to lay out your new countertop dimensions.

Be sure to indicate whether countertop requires Build-up. Specify countertop dimensions, NOT cabinet sizes.

Vanity and Bartops

Measure the width and length of the new cabinets. Indicate location of walls and any end treatment options. See diagram 8 for banjo-top cut around toilet.

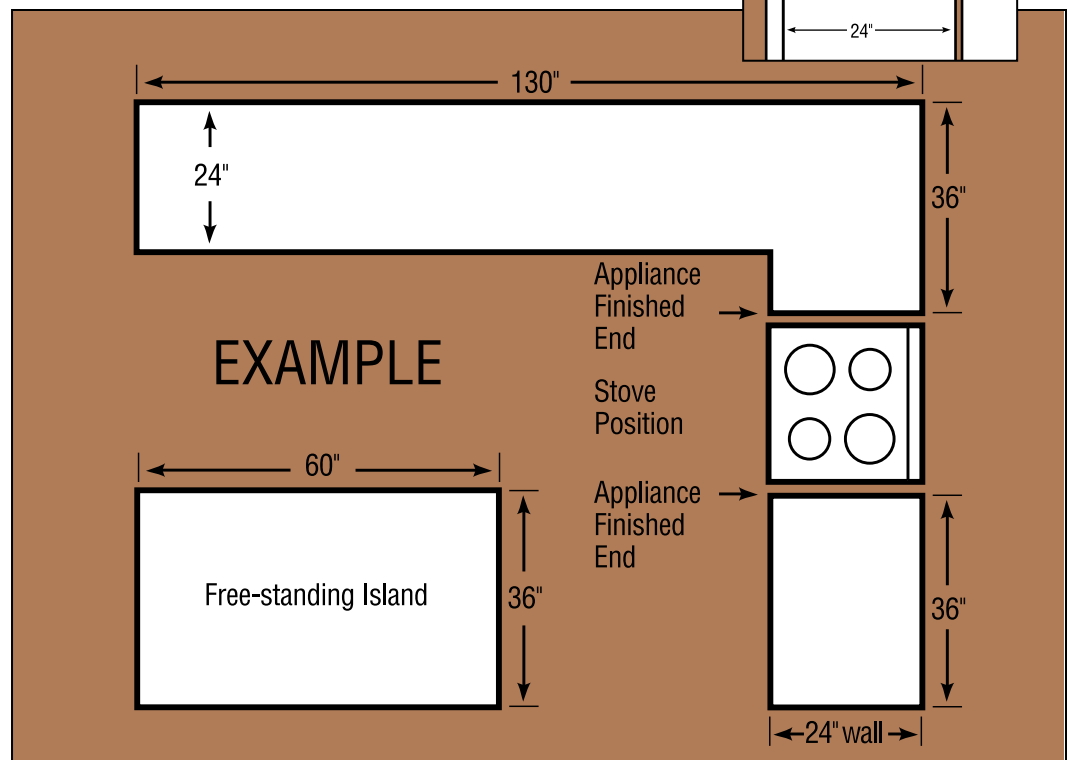
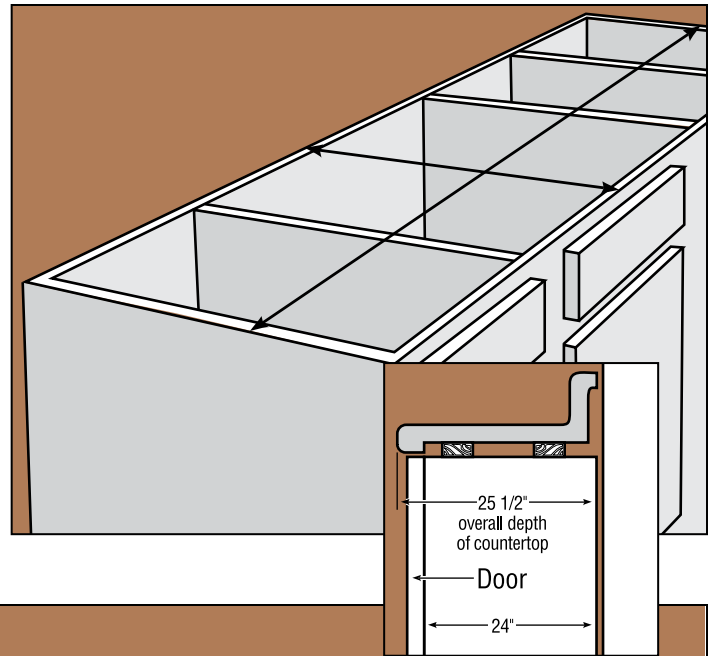

Standard Postform Countertops

Formatop offers a standard range of countertop depths.

- Kitchen countertops 25 1/2" will accommodate standard 24" cabinet depth.
- Bartop standard sizes 26 1/2" - 27", depending on model. Also available in 33", 36", 39" and 42".
- Vanities available in standard sizes 22 1/2" and 23 1/4".

SPECIAL MEASUREMENTS AND CONFIGURATIONS PLUS SERIOUSLY OUT-OF-SQUARE WALLS SHOULD BE DISCUSSED WITH YOUR FORMATOP DEALER.

use a back and forth motion to adhere the laminate. Using a small, smooth wood block, rub the end cap to ensure proper adhesion. When cool (use a wet cloth) file off the excess laminate with a medium wood file. Be careful when filing. Place the file almost parallel to the top of the countertop and file in a single-direction motion. If requested, the end caps can be applied by Formatop.

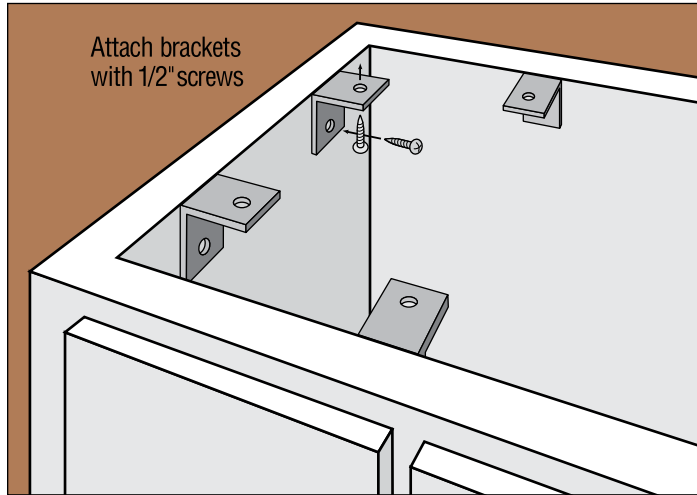

4 Attach 3/4" brackets to the cabinet with 1/2" screws. If there is a horizontal strip of wood on the front and back of the cabinet you may not have to attach brackets.

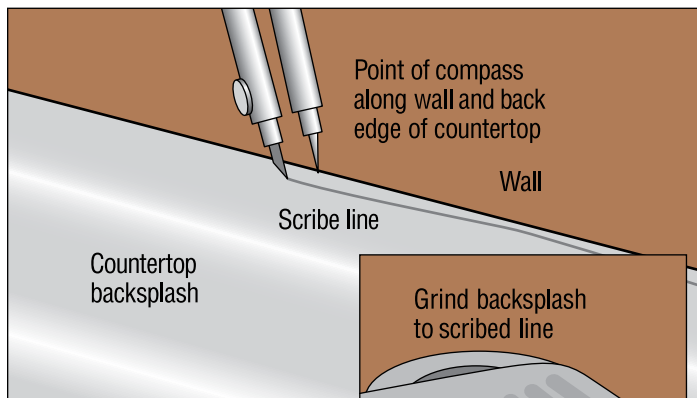

5 Check where countertop meets the wall. If you can see gaps, then your walls may not be straight and even. Open a compass at a point in the largest gap between the wall and the countertop. With the point of the compass always touching the wall, move the compass down the edge, scribing a line along the edge of the countertop backsplash. Remove the countertop, and using a belt sander, grind the backsplash to the scribed line.

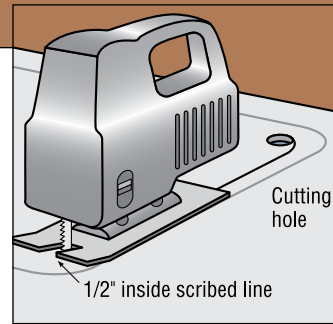
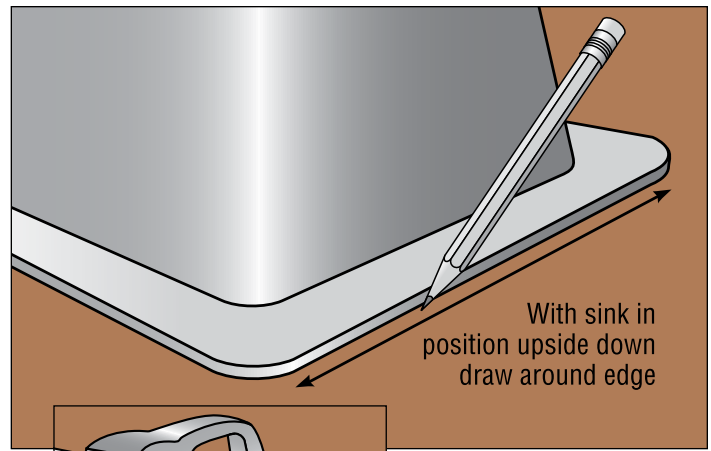

6 Place new countertop on cabinets, making sure of the alignment. Establish position of sink or cooktop. To mark cut-out for self-rimming sink, position the sink upside down on the countertop and trace the outline. Using a straight edge draw a cutting line 1/2" inside the already scribed outline. Drill a pilot hole just inside the cutting line, large enough to accommodate the blade of the jigsaw. Cut along the cutting line with a fine tooth blade and make the corners of the cutout slightly rounded.

NOTE: It is wise to support the cutout area from underneath to prevent damage. Removing the countertop from the cabinets before cutting will eliminate possible damage to the cabinets.

When installing the sink, it is recommended to put waterproof silicone under the rim of the sink to prevent water penetration. The same applies to cooktops.

7 When the countertop is in position on the cabinets apply a bead of waterproof adhesive such as silicone along any mitred edges. Carefully align the countertop pieces and push together tightly. Verify the countertop alignment both front and back.

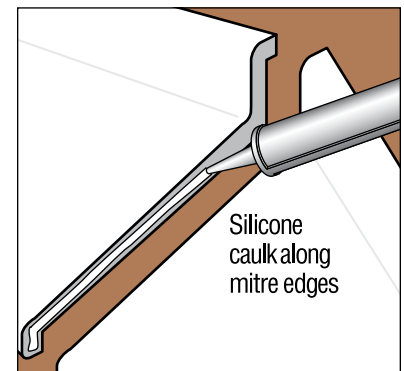

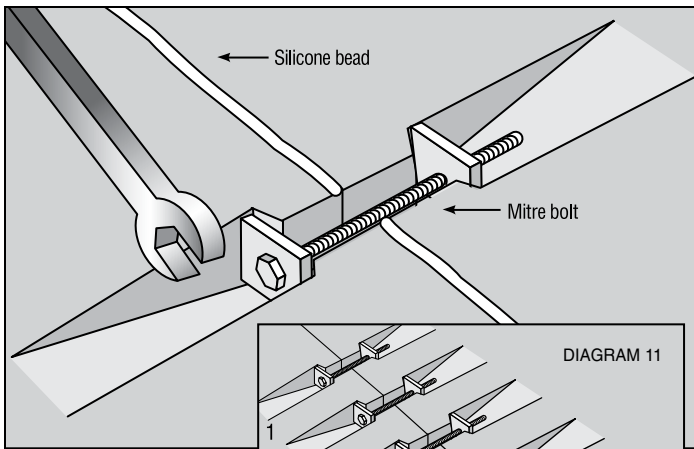

8 From inside of the cabinets and underneath the countertop, install the take-up mitre bolts (supplied with countertop). Install as shown in diagram 11. Tighten only slightly at this point. Check top of countertop, and with a hammer and a piece of wood, tap the mitre joint lightly to obtain a smooth joint. Tighten mitre bolts firmly.

NOTE: For mitred sections 7 ft. x 7 ft. and under, Formatop can supply as a completely assembled unit. Larger units are shipped in sections due to transport and home interior size restrictions.

9 Fix the countertop to the cabinets. Be sure to use the right length of screw so as not to puncture laminate surface. Screw through brackets or wood strips into countertop.

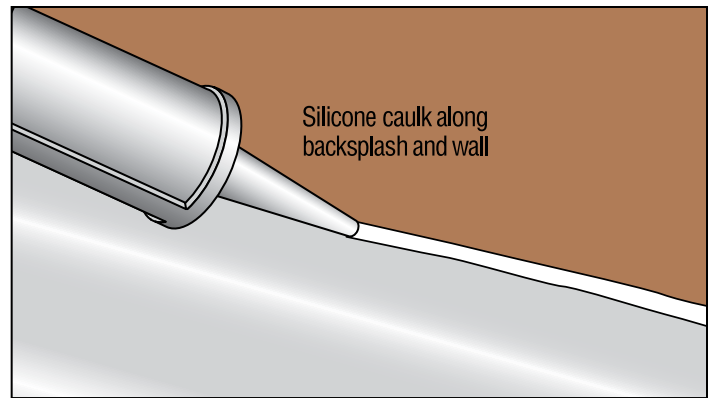

10 To prevent water infiltration apply a small quantity of latex silicone to the mitred edges. Completely wipe off excess. Use silicone to seal edge between countertop backplash and wall. Smooth with wet finger and wipe off excess caulking.

11 Hook up sinks and other appliances.

If you have concerns about installation, contact your Formatop dealer.

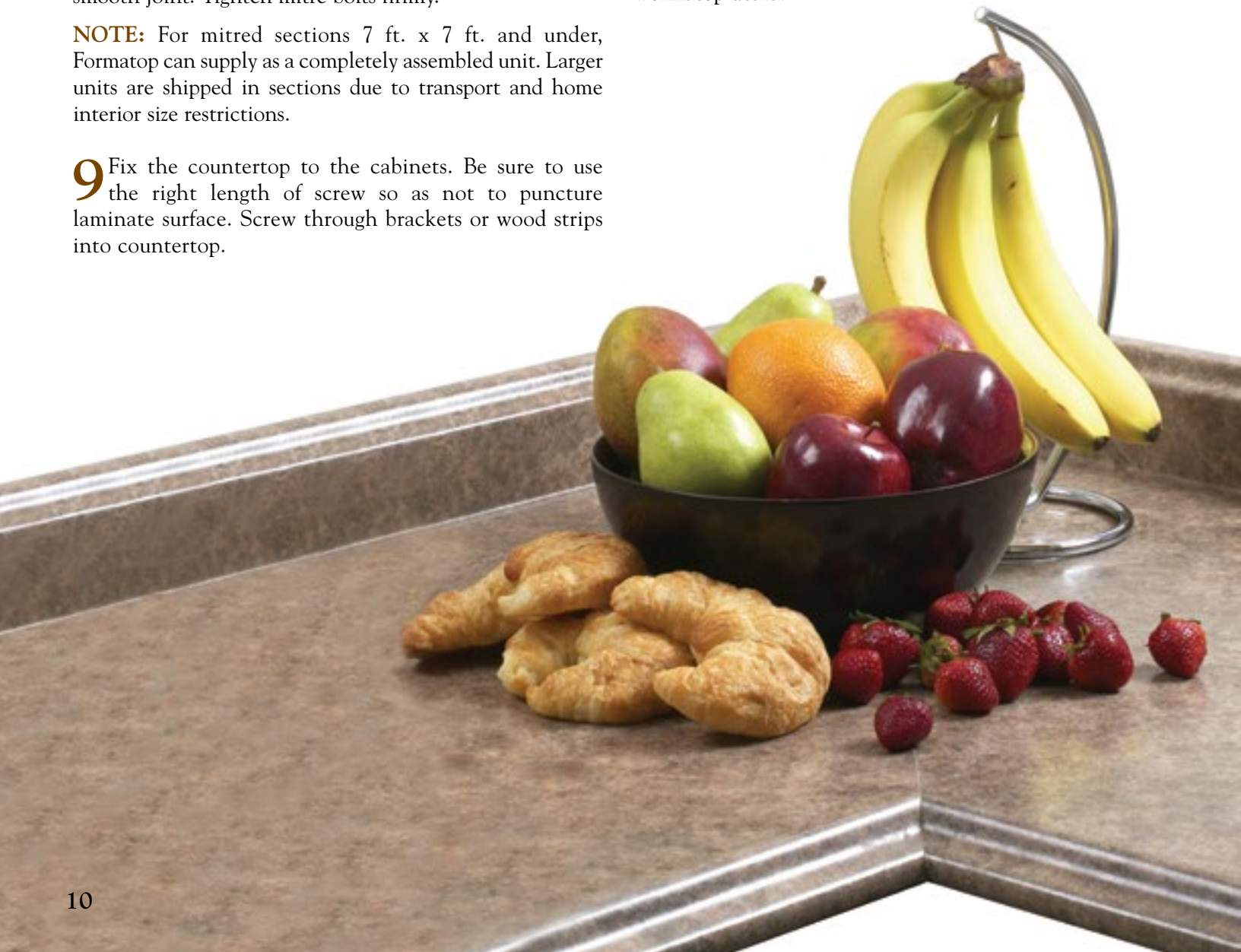

CARING FOR YOUR COUNTERTOPS

Formatop countertops are very durable, but like any product they can be damaged by abuse, neglect or carelessness. When used and cared for properly, your Formatop countertop will give you years of satisfaction.

GUIDELINES

Water Damage

Water that is allowed to sit on the countertop for any length of time, especially near mitre joints, can penetrate and cause the core to swell and eventually delaminate. Be very careful in areas where sinks, dishwashers, coffee makers or kettles are located on or near a mitre joint. Wipe off water or other liquids immediately.

Normal Cleaning

In the majority of cases you can clean your Formatop countertop with a clean, damp, non-abrasive cotton cloth and a mild liquid detergent or household cleaner.

- Rinse with clean water but do not use excess water, especially near mitre joints.
- Dry the surface with a clean, soft, non-abrasive cloth.

Special Cleaning

For matte or sculptured finishes.

- Use a nylon-bristled hand or vegetable brush along with a mild liquid detergent and water solution, or household cleaner.
- Clean the countertop with a rotating motion.
- Rinse and dry the top with a clean, soft, cotton cloth.

If streaks remain after cleaning use a mild glass cleaner and then wipe dry with a soft, non-abrasive, cotton cloth.

GLUE REMOVAL: Any contact adhesive residue on the countertop should be removed by using a reputable, non-flammable, contact adhesive solvent and a non-abrasive, cotton cloth. Use solvent sparingly. Read and follow all instructions and warnings before use.

PAINT AND VARNISH REMOVAL: Use a suitable solvent but use it sparingly. Excessive amounts can delaminate surface. Follow all warnings and instructions. For water-based paints use an ammoniated household cleaner. For stubborn spots use a plastic, non-metallic, non-abrasive pad. Use it gently. **NEVER USE** steel wool or other abrasive scouring pads. These will scratch the surface of the laminate.

STAINS: To remove or minimize stains use a mild, all-purpose, household cleaner and allow it to draw out stain. Blot with clean, damp, non-abrasive, cotton cloth and rinse with cold water. Read and follow all instructions carefully.

Some things can permanently stain the laminate. Newsprint, marking pens, hair dyes, wood stains and other staining agents should be kept away from the countertop. These stains may be reduced by using a paste of baking soda and water to pull out stain. Do not rub. Wipe up paste with clean, damp, non-abrasive, cotton cloth, then rinse and dry. Periodic application of a self-cleaning wax can help minimize future staining.

CAUTION:

Never use cleaners containing acid, alkali, or sodium hypochlorite on the laminate surface. These will mar, etch, corrode and permanently discolour the laminate. Do not place bottles or items containing these cleaners on the laminate surface. Examples: drain cleaners, oven cleaners, ceramic cleaners, coffee pot cleaners, tub and tile cleaners, chlorine bleach, lime scale removers and more.

Scratch and Impact Protection

Under normal use your countertop is very durable, but care should be taken to minimize certain conditions.

Use cutting boards, chopping blocks or other protective elements when working on the countertop. **DO NOT** chop, slice, pound or hammer directly on the laminate surface. Knives or other sharp utensils can slice or scratch surface. Heavy blows from a hammer or meat tenderizer can crack or gouge surface.

Ceramics and abrasive objects can scratch the surface. Use placemats, doilies or trivets to protect surface.

DO NOT use abrasive cleaners, powders, steel wool, sand paper or scouring pads on the laminate surface.

HOT OBJECTS: Do not place hot objects directly on the countertop. Electric skillets, waffle irons, curling irons, hot rollers etc. can damage the surface. Do not iron or place iron on laminate surface. Avoid cigarette contact.

Prolonged exposure to temperatures of 140 degrees F (60 degrees C) or higher may cause the laminate to separate from the core material.

Choice of Surface

Consider the type of use the countertop will receive. Rough textured surfaces have certain advantages over smooth surfaces in high usage areas. High gloss finishes are not recommended for high use areas.



FORMATOP



THE FORMATOP WARRANTY

We warrant our countertops to be free from defects in material and/or workmanship under normal residential usage to the original purchaser for a period of two (2) years from the date of purchase.

This is a parts warranty only and excludes labour for removal or replacement of defective parts. Our obligation under this warranty shall be limited to the repair or replacement of any part or parts that may prove defective under normal residential usage as determined by our examination.

This warranty is expressly in lieu of any and all other warranties, expressed or implied, including warranties of merchantability and of fitness for a particular purpose. This warranty shall not apply to our countertops or parts of our countertops that have been subjected to alteration, misuse, negligence, abuse, improper installation, storage and handling.

Copyright 2016. All rights reserved.

For more information talk to your authorized Formatop dealer or contact Formatop at:

1530 & 1548 Strasburg Road,
Kitchener, Ontario N2R 1E9

Phone: (519) 748-4928 Fax:
(519) 748-4579

Toll-free: 1-888-237-0037

www.formatop.com

Your authorized Formatop dealer: